

FOUR THINGS

TO DO WHICH WILL HELP THIS COLEMAN INSTANT-LIGHTING LANTERN GIVE YOU BETTER SERVICE AND LONGER SERVICE

1. Always use a good grade of fresh, clean, water-white gasoline. Do not use any of the doped, anti-knock or Ethyl gasolines in this appliance.
2. If a suitable unleaded fuel is not available, then ask your service station operator to contact his company in an attempt to secure for you a special stove and lighting fuel or naphtha. Most of the major oil companies have such fuels available.
3. Read and carefully follow instructions given in this directions folder. If you will do this, you will avoid difficulties that result from improper operation and which are due to no fault of the Lantern.
4. Keep the fount of the Lantern clean. This prevents the residue which may collect at the bottom of the fount from stopping up the generator (see Par. 7).

This Directions Folder is Written for Your Convenience. It is Worth While To Follow Instructions Carefully Step by Step.

ALWAYS USE GENUINE COLEMAN JUNIOR MANTLES



1. They are made without side seams and are pleated or gathered across the bottom, thus reinforcing them at the point where they are subjected to the greatest gas pressure.
2. They are made especially for Coleman Lamps and Lanterns. They are just right in size, shape and texture. They are given just the right chemical treatment. They work perfectly with the gas tip and air intake in producing the splendid brilliance for which the Coleman Lamps and Lanterns are famous.

We cannot guarantee either the quality or quantity of light produced by any Coleman Lamp or Lantern if an inferior low-grade mantle is used on it. So take no chances. Always insist on Genuine Coleman Mantles.

For maximum life and lowest cost service we recommend our Heavy Duty Grade A Silk Lite Mantle No. 21A.

SUGGESTIONS

About Care and Use of Coleman Instant-Lighting Lantern Models 220E, 228E

If Lantern Blazes up and Smokes for more than a few seconds while you are Instant-Lighting it then close Valve and as soon as light starts to dim reopen Valve to one-fourth turn.

If Lantern Does Not Light, make sure there is plenty of air pressure and gasoline in Fount. Remove Generator and unscrew Gas Tip to make sure that point of Needle has not been bent or curled. Open Valve slightly to make sure raw gasoline will come through.

If Mantle Turns Black, make sure Screens in Burner Caps are clean and open. Check Air Intake Tube for a possible obstruction such as a spider's nest.

If Light Grows Dim, perhaps Valve has not been opened all the way after Lantern has been Instant-Lighted. Rotate Cleaning Lever on side of Valve to remove carbon, if any, from Orifice in Generator Gas Tip.

If Light Has a Tendency to Pulsate or flicker slightly after a new Generator has been installed, then pump additional air pressure into the Fount until the situation is corrected.

If Lantern is To Be Kept On Hand for standby emergency use in case of storm or power line failure, then empty all gasoline from the Fount and after Fount has cooled, refill with clean, fresh gasoline. Keep Lantern in as cool a place as possible.

To Test Built-In Pump for an air pressure leak, tip the Fount over so you can hold the end of the Pump in a full glass of water.

If You Have Occasion to Write the dealer or the factory, indicate whether your Lantern is a No. 220E or No. 228E.

If You Have to Mail the Lantern in for Service Attention, then send it less the Pyrex Globe and Ventilator to avoid breakage.

Parts List for Coleman Instant-Lighting Lantern Models 220E, 228E

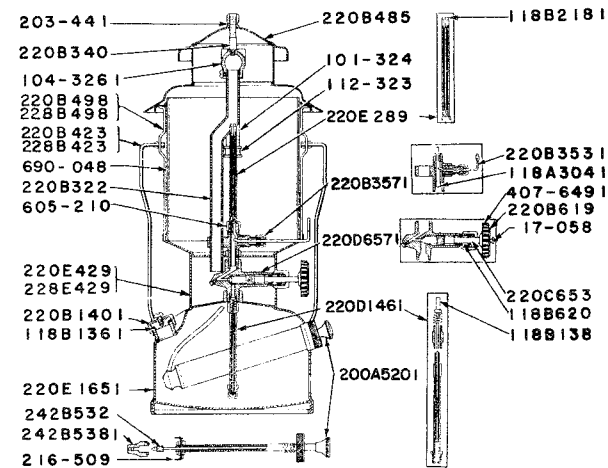

Part No.	Nomenclature	Price
17-058	Screw for Valve Wheel	\$.03
**021A306	(21A) Mantle15
101-324	Burner Tube33
104-147	Lock Nut15
104-3261	Mixing Chamber87
112-3231	Burner Cap and Screen18
**118A3041	Eccentric Block21
118B1361	Filler Plug Gasket06
118B138	Fuel Tip Cleaning Needle21
118B2181	Gas Tip (Marked "V")09
118B620	Valve Stem Packing06
200A5201	Pump Plunger Complete	1.11
203-441	Ventilator Ball Nut15
216-509	Pump Leather09
220B1401	Filler Plug Complete66
220B322	Air Intake Tube72
220B340	Ventilator Rod15
**220B3531	Tip Cleaner Stem (Packed)75
220B3571	Gas Tip Cleaner Complete	1.20
*220B423	Bail18
*220B485	Ventilator	1.44
*220B498	Frame and Bail	1.02
220B619	Direction Disc09
**220B950	Wrench (Small)09
220C6531	Valve Stem Complete93
220D1461	Fuel and Air Wire Complete69
220E1651	Fount Complete	5.22
220E2891	(T44DL) Generator	1.00
220D6571	Fuel Valve Complete	1.80
*220E4291	Base Rest36
†227-480	Ventilator	2.19
†228B423	Bail21
†228B498	Frame and Bail	1.05
*228E429	Base Rest24
242B532	Air Stem36
242B5381	Check Valve39
407-6491	Valve Wheel39
605-210	Jamb Nut09
605-950	Wrench (Large)27
690-048	(330) Pyrex Glass Globe	1.25

*For Lantern Model No. 220E (Also 220C, 220B and 220D)

†For Lantern Model 228E (Also 228C, 228B and 228D)

**Not illustrated

Prices Subject to Change Without Notice.

OPERATING DIRECTIONS

for

Coleman INSTANT-LIGHTING LANTERN

Models 220E and 228E



Made in the United States of America

The Coleman Company, Inc.

General Office and Factory: WICHITA 1, KANSAS, U.S.A.

Canadian Office and Factory: Toronto, Canada

Sales Offices: Philadelphia 40; San Francisco 3; Los Angeles 1

F666C

Printed in U.S.A.

ICCC/OCP

Directions for
Assembling and Operating

Coleman
INSTANT-LIGHTING
LANTERN
Models 220E and 228E

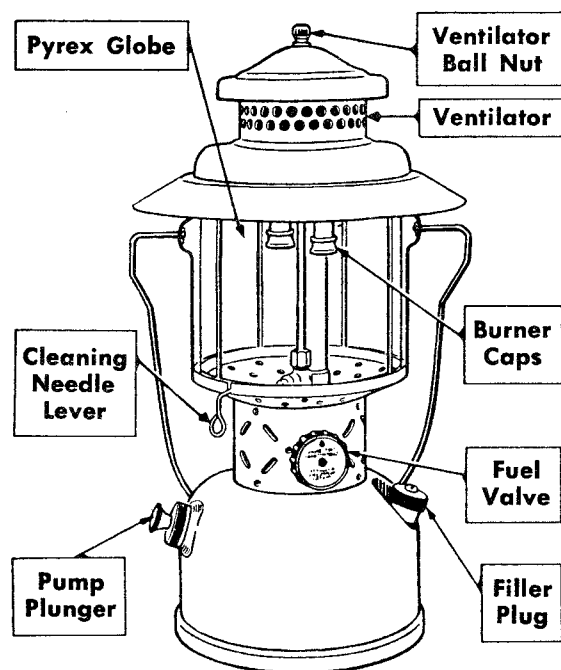

Carefully following directions and using "Approved" gasoline will insure long and satisfactory service.

DO NOT USE DOPED, ANTI-KNOCK OR COLORED GASOLINES

1. TO FILL —

Be sure Fuel Valve is tightly closed to right. Then remove Filler Plug and fill Fount with two pints of fresh, clean, water-white, undoped gasoline (also known as "Petrol," "Motor Spirits," "Essence"). Do not tip Lantern while filling. Let it sit flat on its base. When filling the Fount strain the gasoline through several thicknesses of finely woven cloth. Or, better still, use the new Coleman Filtering Funnel, No. 0, which removes water and dirt from the gasoline. Your dealer can supply you. As soon as Fount is filled, replace Filler Plug and tighten firmly with fingers.

2. TO PUMP —

See that Fuel Valve is closed. Then open air Check Valve (inside of pump barrel) by turning Pump Plunger two full turns to left. Place ball of thumb over small hole in end of Pump Plunger and pump 35 to 40 full strokes of air into Fount. Now turn Pump Plunger to right, seating Air Stem in Check Valve, remove thumb and push Pump Plunger back into pump barrel.

Good Pressure is important. Keep Pump Leather soft with few drops of oil.

3. TO PUT ON MANTLES —

Unscrew Ventilator Ball Nut on top of Lantern, and remove Ventilator and Pyrex Globe.

Tie mantles to grooves in Burner Caps with flat side of mantles parallel to Generator.

Distribute folds of mantles evenly at top and cut off surplus string.

Then burn off mantles following directions on mantle envelope. Allow mantles to cool several minutes before lighting Lantern.

4. TO LIGHT —

(a) At the base of the lantern frame you will note the Cleaning Needle Lever. When turned around this Lever causes the Gas Tip Cleaning Needle inside the Generator to work up and down. This keeps the Gas Tip clean and open. Turn the Lever several revolutions before lighting. Be sure the Lever is left pointing down.

(b) Have a match handy ready to light. Now open the Fuel Valve **one-fourth turn**. This is important—open it **one-fourth turn only**. Then light the match and hold it under the mantles. It may require a few seconds for the gas to reach the mantles but when it does mantles will light instantly. After the mantles burn bright open Fuel Valve as far as possible, which is about three full turns. **This is important and must be done** in order to get good light. It is impossible to open the Fuel Valve too far. **After lighting Lantern pump in additional pressure to insure long operation.**

The Cleaning Needle Lever may be operated while Lantern is burning. Should Lantern fail to burn bright after Fuel Valve is wide open, turn Cleaning Needle Lever rapidly two or three times.

NOTE—The light may flicker for a few seconds after lighting but it will soon steady down.

5. TO TURN OUT LIGHT —

Rotate cleaning needle lever several times. Turn fuel valve to right until closed. The light will dim and go out in a few seconds.

6. TO CHANGE GENERATORS —

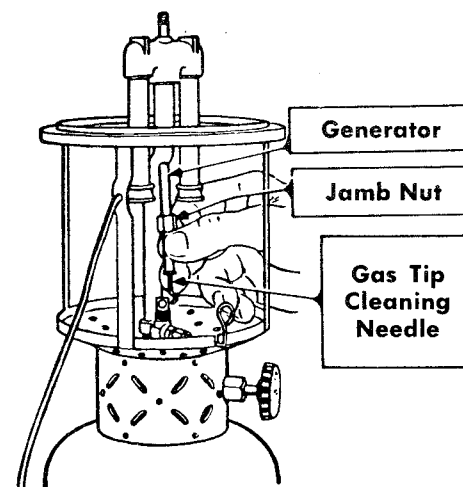

First be sure Fuel Valve is closed. Then turn Cleaning Needle Lever up. Unscrew Jamb Nut at lower end of Generator. Lift Generator up and unhook Gas Tip Cleaning Needle. Then pull Generator with

Cleaning Needle down and out. To install new Generator with Cleaning Needle: First pull Cleaning Needle down about 1". Place Cleaning Needle between forefinger and thumb, holding Generator in upright position. Push Generator through opening in Air Intake Tube, and hook Cleaning Needle in hole of Cleaning Block. Now turn Cleaning Needle Lever down, seat Generator properly. Screw Jamb Nut down, tightening with Wrench.

7. KEEP FOUNT CLEAN —

Rinse the Fount occasionally in order to prevent an excessive accumulation of sediment or moisture in the Fount. Contents of the Fount may be poured out through the Filler Plug Bushing.

8. KEEP BURNER PARTS CLEAN —

Each time before installing a new Mantle use a bristle brush, such as a discarded tooth brush, to clean the Screen in the Burner Cap.

THE PUMP PLUNGER is not only used for pumping air pressure into the Fount but it acts as a wrench to turn the Air Stem. Turning the Plunger to the left unscrews the Air Stem so that air may be forced through the Check Valve at the bottom of the Pump Barrel. Turning the Pump Plunger to the right screws the Air Stem into the Check Valve to provide a positive shut-off at that point. Air pressure may be added while Lantern is burning. Oil the leather occasionally for greater efficiency.

IF LANTERN IS TO BE LEFT UNUSED for several days or weeks, it would be well to empty the gasoline from the Fount. This would prevent the gasoline from souring and forming gum in the Fount.

TO TEST BUILT-IN PUMP for an air pressure leak, tip the Fount over so you can hold end of Pump in a full glass of water.